

FlexCore 2000

Category II or Category IV Appliance
(see Installation and Operation Manual for venting information)

CODE OPTIONS

CSD-1	STANDARD
-------	----------

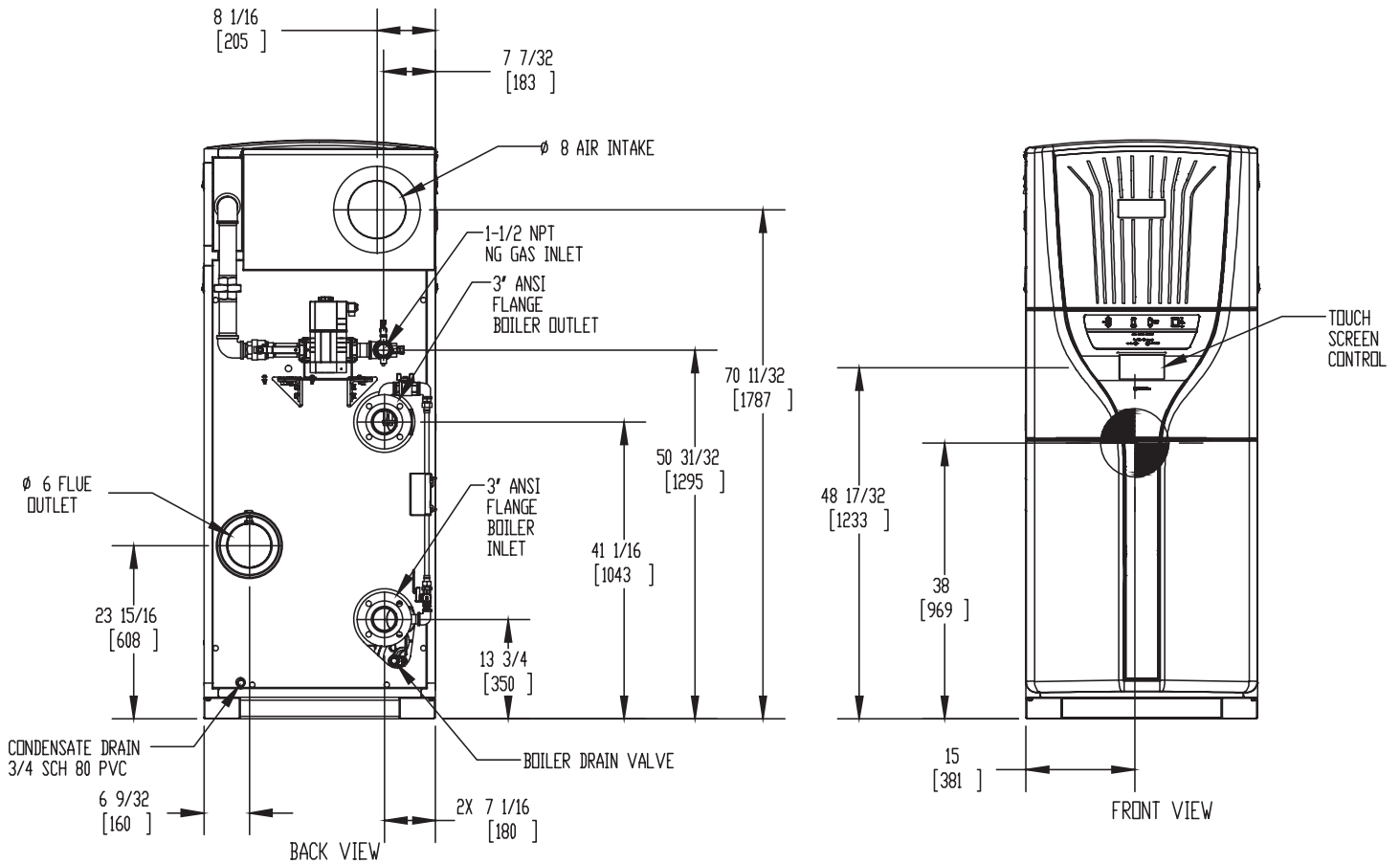

Notes:

1. Dimensions are approximate and should not be used to "rough-in" equipment.
2. Dimensions are subject to change without notice.
3. All dimensions are in inches (mm).
4.  Symbol indicates center of gravity.

FlexCore 2000

Category II or Category IV Appliance
 (see Installation and Operation Manual for venting information)

CODE OPTIONS

CSD-1	STANDARD
-------	----------

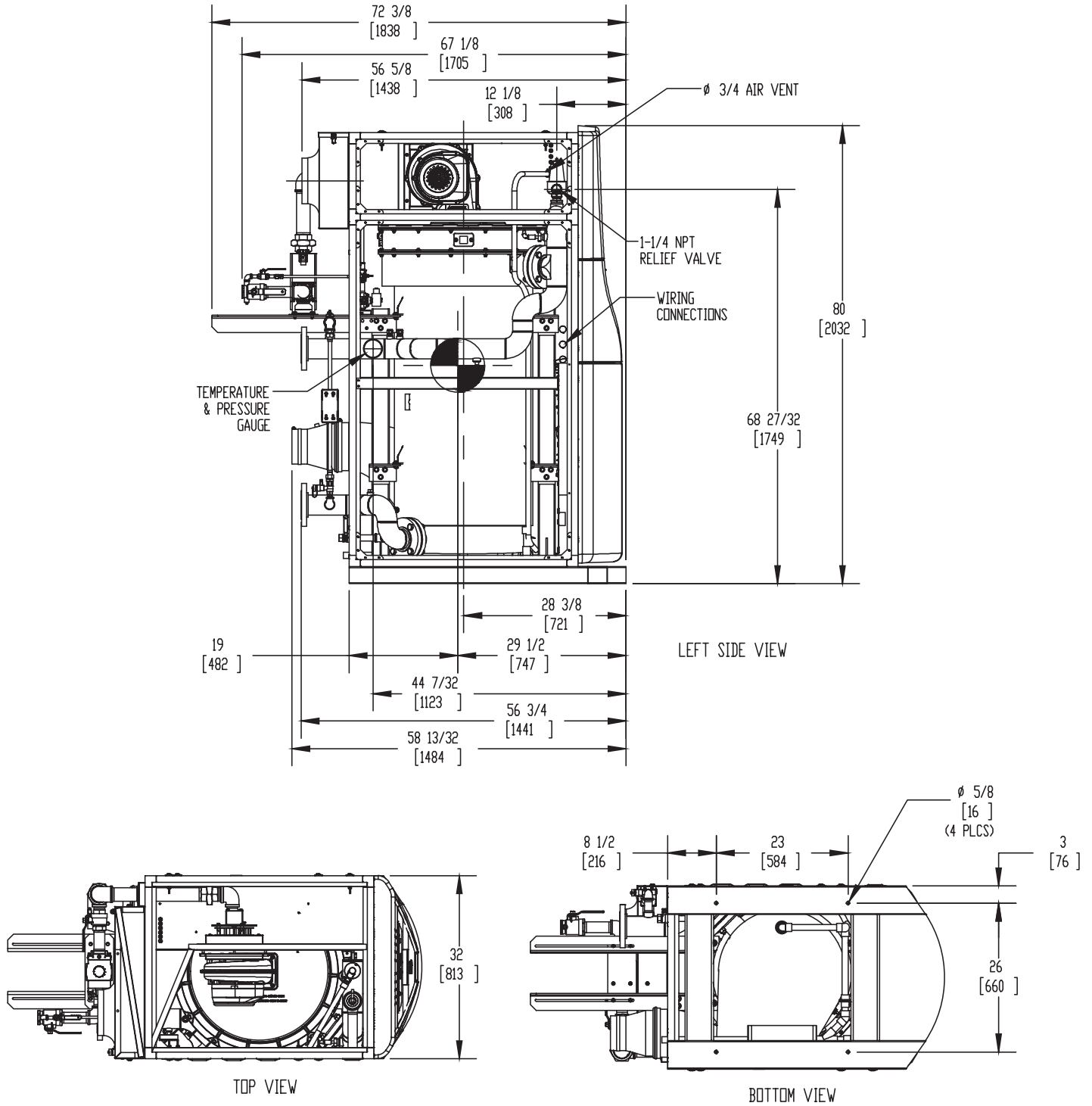

Notes:

1. Dimensions are approximate and should not be used to "rough-in" equipment.
2. Dimensions are subject to change without notice.
3. All dimensions are in inches (mm).
4. ● Symbol indicates center of gravity.

BOILER CERTIFIED RATINGS & CAPACITIES

Fuel Type	Natural Gas	Boiler FLA	13.0*
Input BTU/hr.	1,999,000 / 586 KW	Boiler HP	56.8
Output BTU/hr.	1,901,049 / 557KW	Min. Gas Pressure Required	3" W.C.
Electrical Requirements	230 VAC/60 Hz/1PH (with neutral)	Max. Gas Pressure Allowed	14" W.C.
		Operating Weight	2290 lbs. / 1039 kg.

BOILER TRIM & CONTROLS

Main Gas Valve	Dungs MBC	Air Switch	Huba
Firing Valve	1 1/2" Apollo	Flow Sensor	SIKA
Ignition Control	Honeywell RM7895C	Blocked Flue Switch	Cleveland NS2
Operating Control	HeatNet®	Blower Motor	Ametek
High Limit	Jumo	L.W.C.O.	800
Main Ball Valve	1 1/2" Apollo	Relief Valve	1" x 1-1/4" set @ 50 psi
Pilot Cock	1/4"	Pilot Regulator	White-Rodgers

A.S.M.E.

ASME Sect IV Fire Side Htg Surface	168 Sq. Ft. / 15.6 Sq. M.	Design Data	Max. 160 psig & 210°F
ASME Sect IV Water Side Htg Surface	174 Sq. Ft. / 16.2 Sq. M.	Water Volume	62 gal / 234 liters
CV. GPM (1PSID)	93		

* Add circulator amps.

BOILER TEMPERATURE RISE / PRESSURE DROP (Based on Full Input)

20°F / 11.1°C		40°F / 22.2°C				60°F / 33.3°C				80°F / 44.4°C				100°F / 55.5°C					
Flow Rate		Pressure Drop		Flow Rate		Pressure Drop		Flow Rate		Pressure Drop		Flow Rate		Pressure Drop		Flow Rate		Pressure Drop	
GPM	L/s	Ft	kPa	GPM	L/s	Ft	kPa	GPM	L/s	Ft	kPa	GPM	L/s	Ft	kPa	GPM	L/s	Ft	kPa
190.2	12.0	9.6	28.8	95.1	6.0	2.4	7.2	63.4	4.0	1.1	3.2	47.5	3.0	0.6	1.8	38.0	2.4	0.4	1.2

Flow GPM		Temp. Rise** (°F)		Vent Length (Equiv. Ft.)		Air Inlet Length (Equiv. Ft.)	
Min	Max	Min	Max	Min	Max	Min	Max
38.0	190.2	20	100	6	100	0	100

** Min/Max delta t reflects boiler operation at full input. For applications requiring operation above/below these parameters please consult factory.

REP FIRM _____
SUBMITTED BY _____
JOB NAME _____
ARCHITECT _____
ENGINEER _____
CONTRACTOR _____
DATE _____

FlexCore 2000

Category II or Category IV Appliance
(see Installation and Operation Manual for venting information)



A Division of Mestek, Inc.
Westfield, MA 01085
(413) 564-5515